

# 80

# DC Fan Series x80x15mm

UL us CE RoHS

Optional Features



## GENERAL SPECIFICATIONS

Bearing Type: Sleeve Bearing & Ball Bearing  
 Material: Impeller & Frame: Plastic (UL94V-0)  
 Lead Wire: UL Type  
 Operation Temperature: -10°C-70°C, 35%-85%RH  
 Storage Temperature: -40°C-80°C, 35%-85%RH

## SPECIFICATIONS

Model	Bearing System		Rated Voltage	Operation Voltage	Rated Current	Rated Speed	Air Flow	Air Pressure	Noise Level	Weight
	Ball	Sleeve	VDC	VDC	A	RPM	CFM	mmH <sub>2</sub> O	dBA	g
SD8015H1X	●	●	12.0	6.0-13.8	0.25	3000	31.2	2.6	35	54
SD8015M1X	●	●			0.18	2500	26.0	1.9	30	
SD8015L1X	●	●			0.10	2000	20.8	1.2	25	
SD8015H2X	●	●	24.0	12.0-27.6	0.15	3000	31.2	2.6	35	
SD8015M2X	●	●			0.13	2500	26.0	1.9	30	
SD8015L2X	●	●			0.10	2000	20.8	1.2	25	

## DIMENSIONS DRAWING

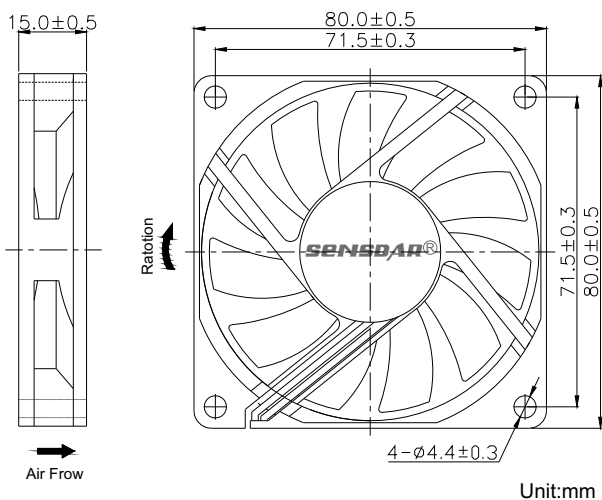

## P&Q CURVE (AT RATED VOLTAGE)

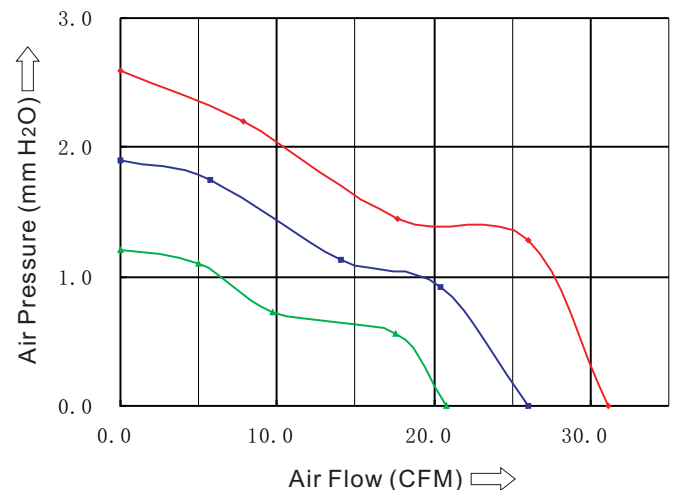

Note:

- \*All readings are typical values at rated voltage.
- \*Specifications are subject to change without prior notice.
- \*"X" in model list can be B, S, and C, meaning Dual Ball Bearing, Sleeve Bearing and 1 Ball 1 Sleeve Bearing