

Bridge Rectifiers

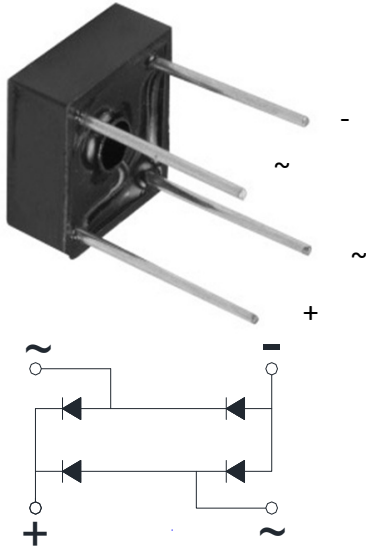

Features

- UL recognition, file #E230084
- Suitable for printed circuit board or chassis mounting
- Compact construction
- High surge current capability
- Solder dip 275 °C max. 7s, per JESD 22-B106

Typical Applications

The KBPC series of single phase rectifier bridge consists of four silicon junctions connected as a full bridge. These devices are intended for general use in industrial and consumer equipment.

Mechanical Data

- **Package:** KBPC8
Molding compound meets UL 94 V-0 flammability rating, RoHS-compliant
- **Terminals:** Tin plated leads, solderable per J-STD-002 and JESD22-B102
- **Polarity:** As marked on body

■ Maximum Ratings (T_a=25°C Unless otherwise specified)

PARAMETER	SYMBOL	UNIT	KBPC10005	KBPC1001	KBPC1002	KBPC1004	KBPC1006	KBPC1008	KBPC1010
Device marking code			KBPC10005	KBPC1001	KBPC1002	KBPC1004	KBPC1006	KBPC1008	KBPC1010
Repetitive Peak Reverse Voltage	VRRM	V	50	100	200	400	600	800	1000
Average Rectified Output Current @60Hz sine wave, R-load, T _a =40°C	I _O	A	10						
Surge(Non-repetitive)Forward Current @60Hz Half- sine Wave, 1 cycle, T _a =25°C	I _{FSM}	A	180						
Current Squared Time @1ms≤t≤8.3ms T _j =25°C, Rating of per diode	I ² t	A ² S	135						
Storage Temperature	T _{stg}	°C	-55 ~+150						
Junction Temperature	T _j	°C	-55 ~+150						

■ Electrical Characteristics (T_a=25°C Unless otherwise specified)

PARAMETER	SYMBOL	UNIT	TEST CONDITIONS	KBPC10005	KBPC1001	KBPC1002	KBPC1004	KBPC1006	KBPC1008	KBPC1010
Maximum instantaneous forward voltage drop per diode	V _{FM}	V	I _{FM} =5A	1.1						
Maximum DC reverse current at rated DC blocking voltage per diode	I _{RRM}	μA	V _{RM} =V _{RRM}	10						

■ Thermal Characteristics (T_a=25°C Unless otherwise specified)

PARAMETER	SYMBOL	UNIT	KBPC10005	KBPC1001	KBPC1002	KBPC1004	KBPC1006	KBPC1008	KBPC1010
Thermal Resistance Between junction and ambient	R _{θJ-A}	°C/W	19						

■ **Ordering Information (Example)**

PREFERRED P/N	PACKAGE CODE	UNIT WEIGHT(g)	MINIMUM PACKAGE(pcs)	INNER BOX QUANTITY(pcs)	OUTER CARTON QUANTITY(pcs)	DELIVERY MODE
KBPC10005~KBPC1010	A1	Approximate 4.75	200	200	2000	Paper Box

■ **Characteristics (Typical)**

FIG1:Io-Ta Curve

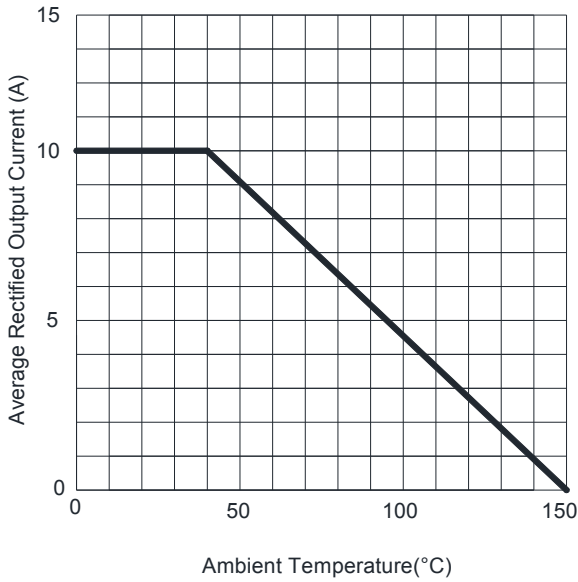

FIG2:Surge Forward Current Capability

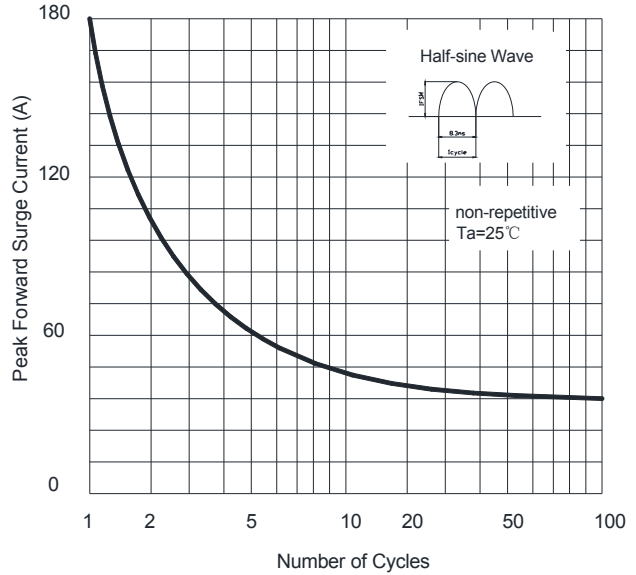

FIG3:Instantaneous Forward Voltage

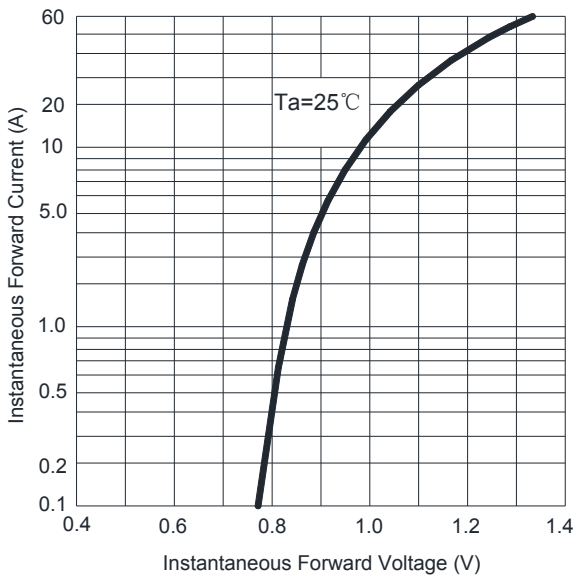
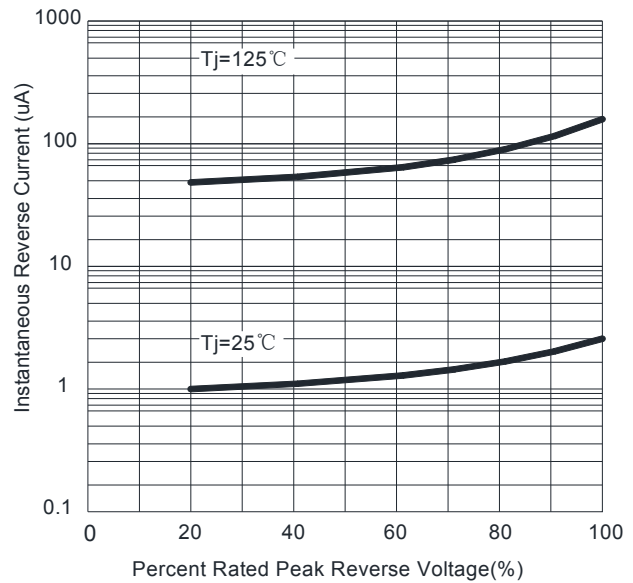
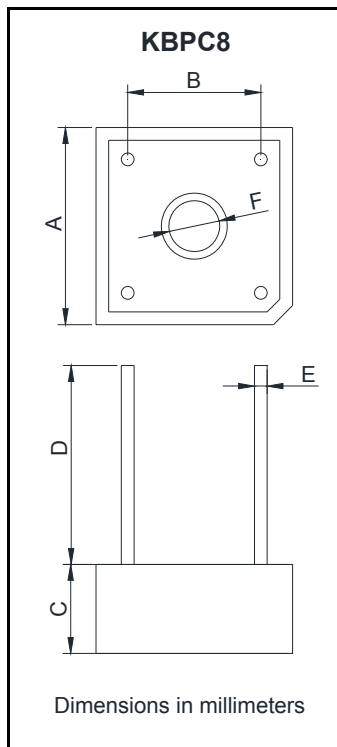

FIG4:Typical Reverse Characteristics



■ Outline Dimensions



KBPC8		
Dim	Min	Max
A	18.54	19.58
B	12.2	13.2
C	6.35	7.6
D	15.0	/
E	1.2	1.3
F	3.8	4.2