

B - B

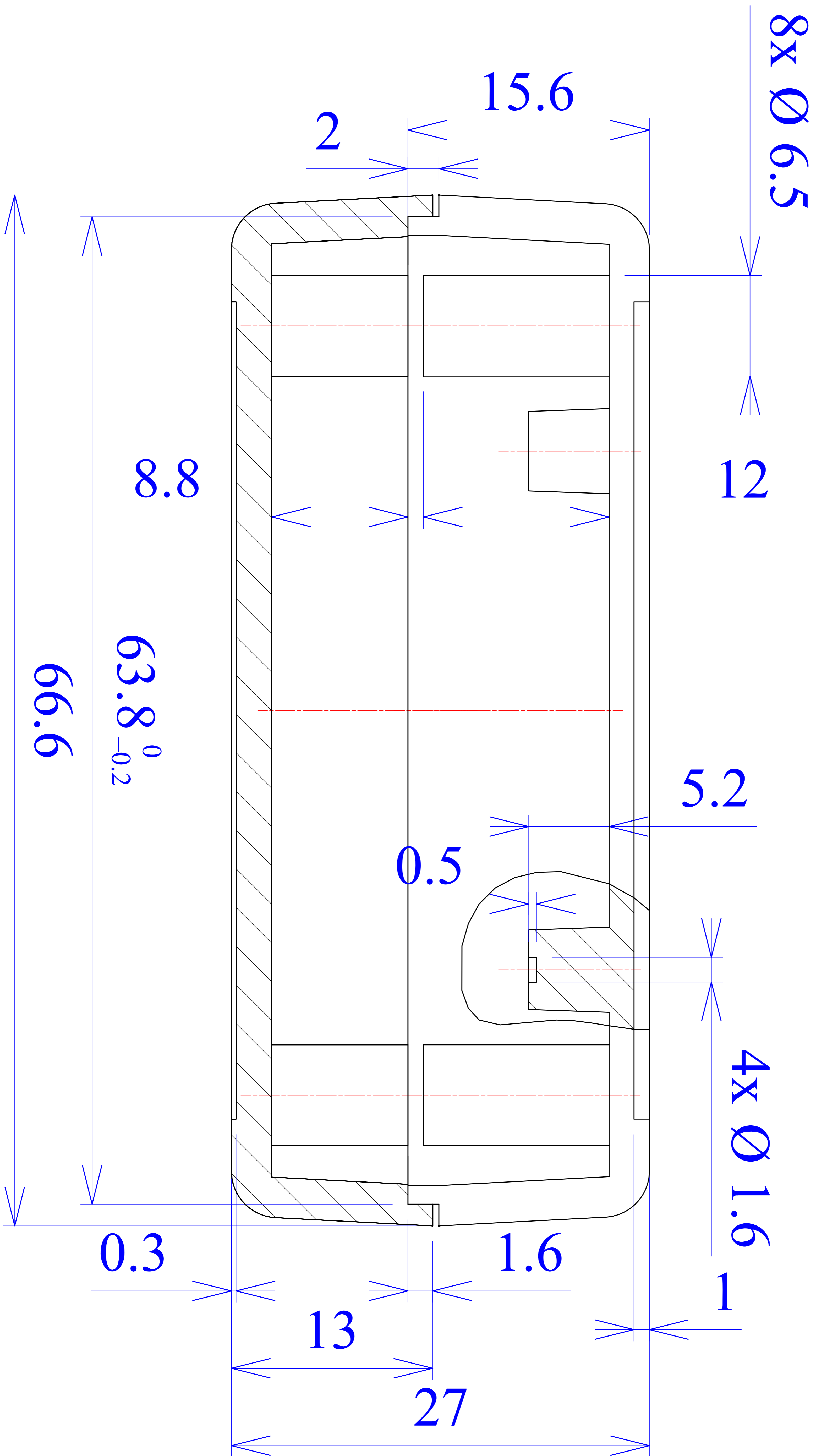

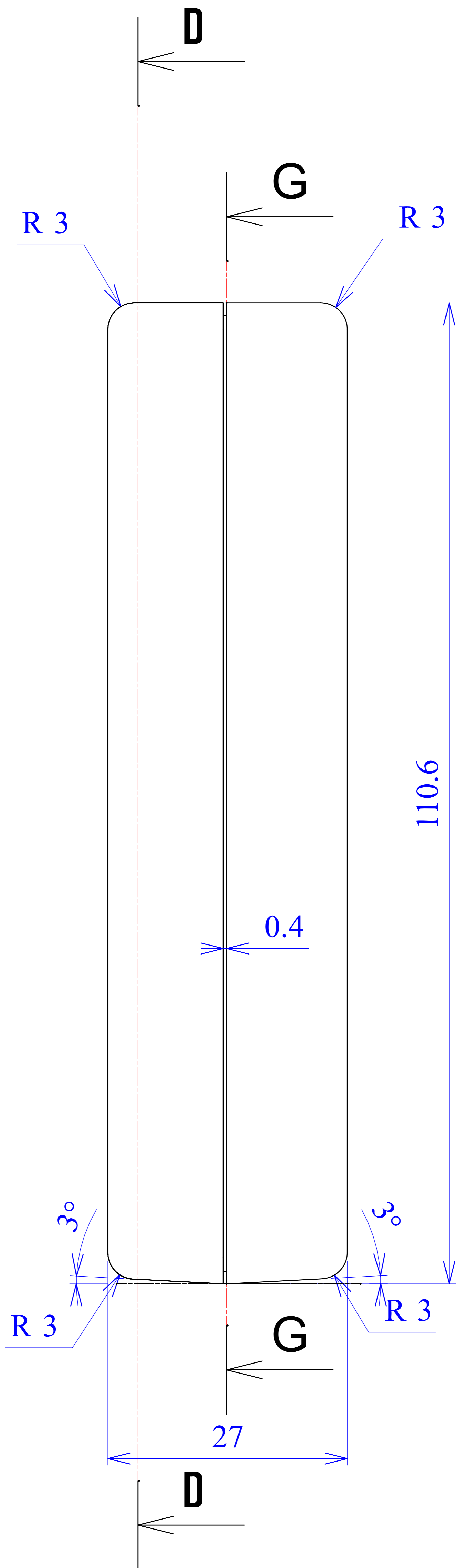

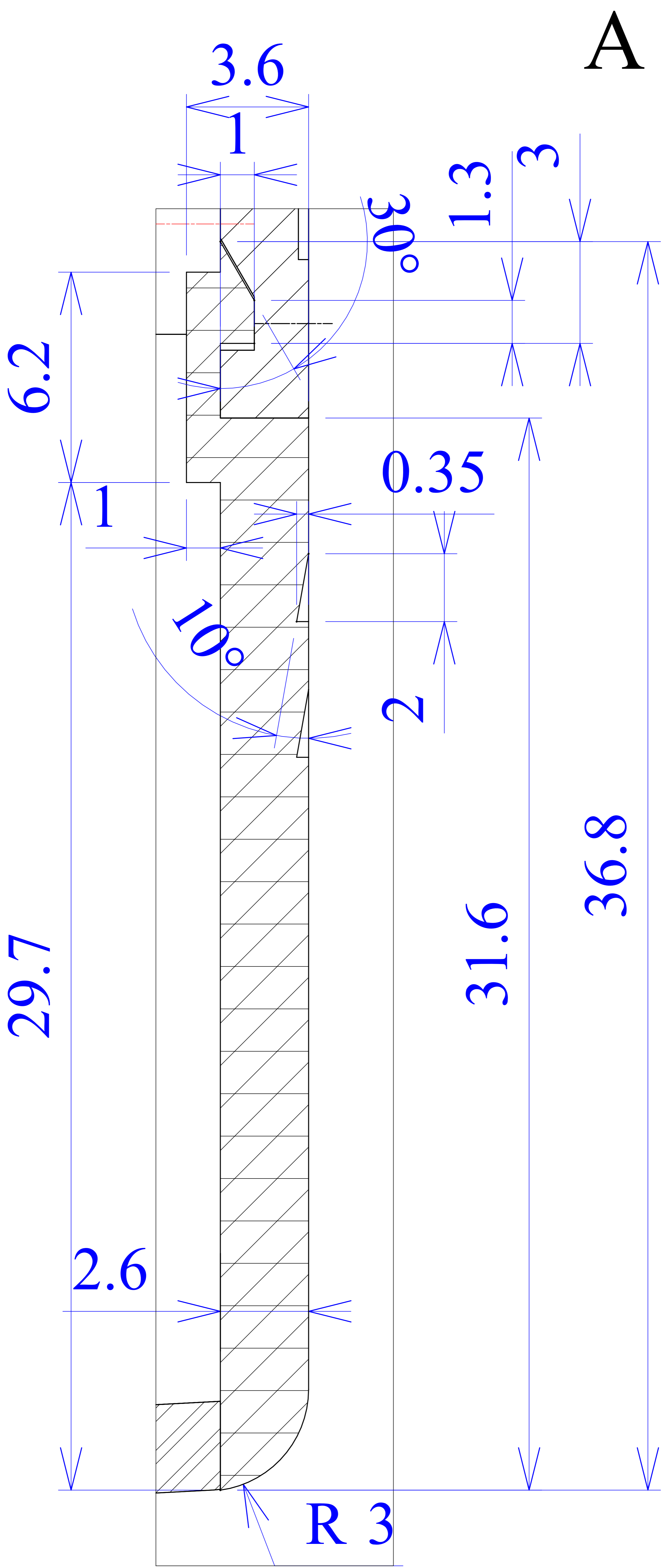

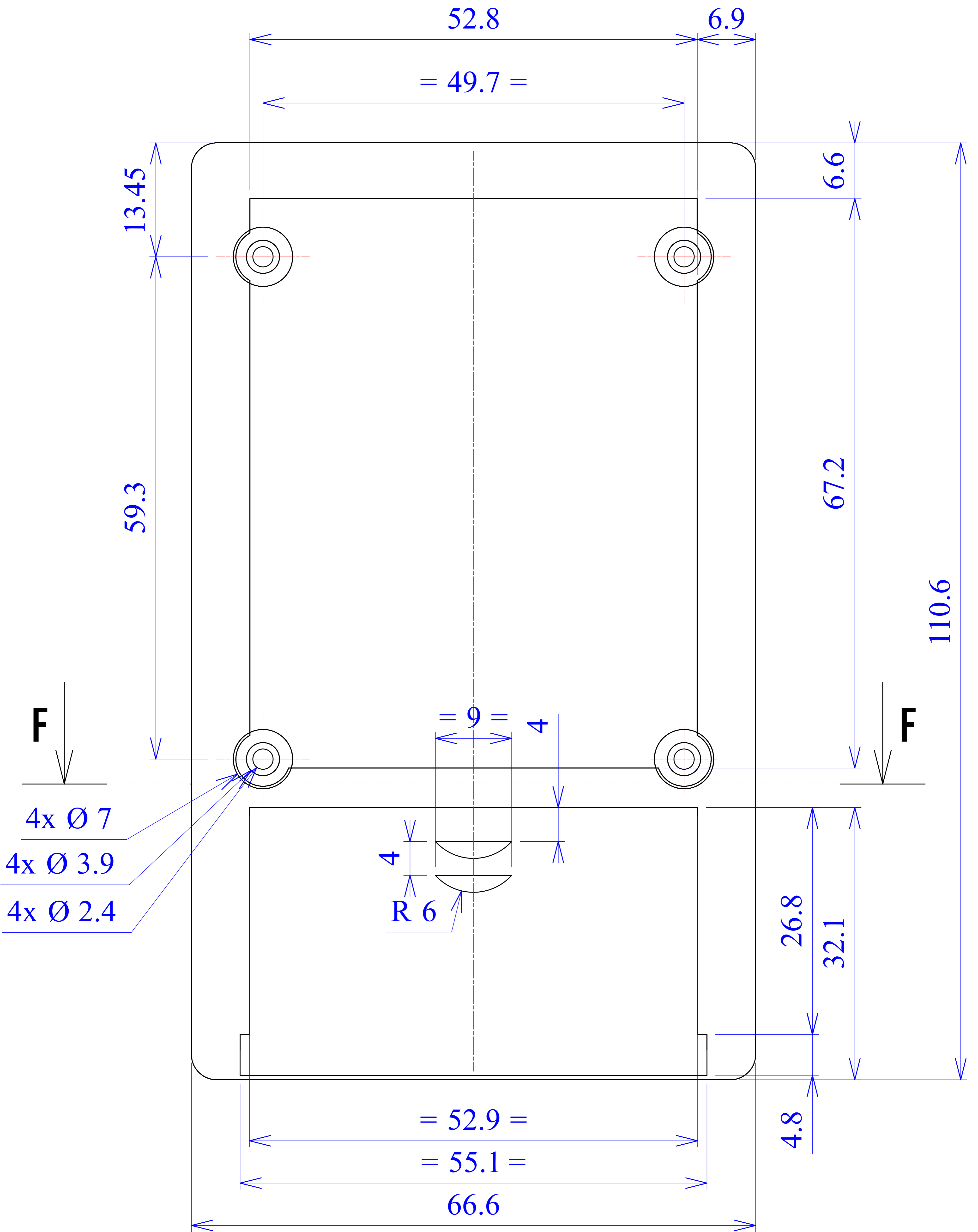

G - G

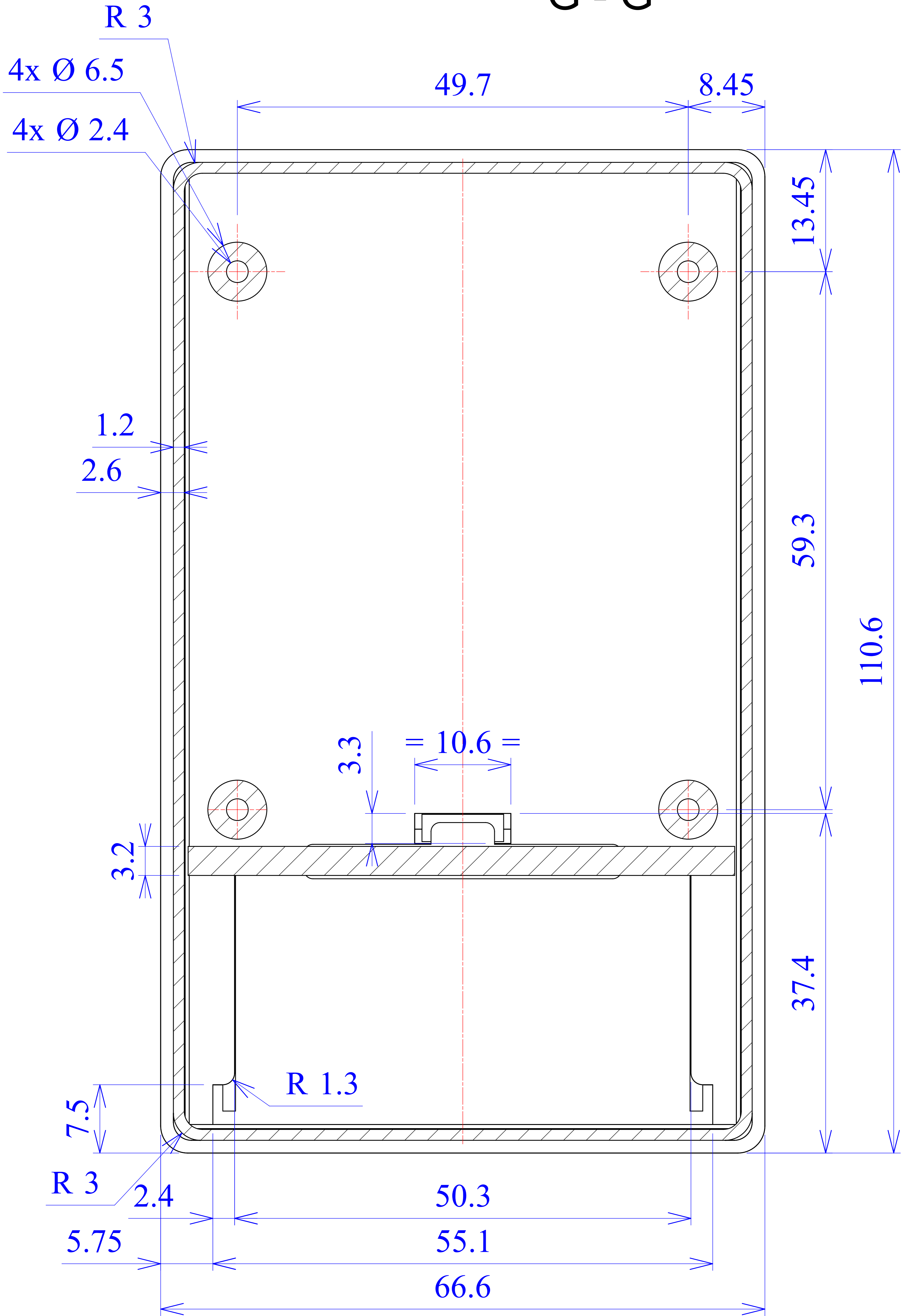

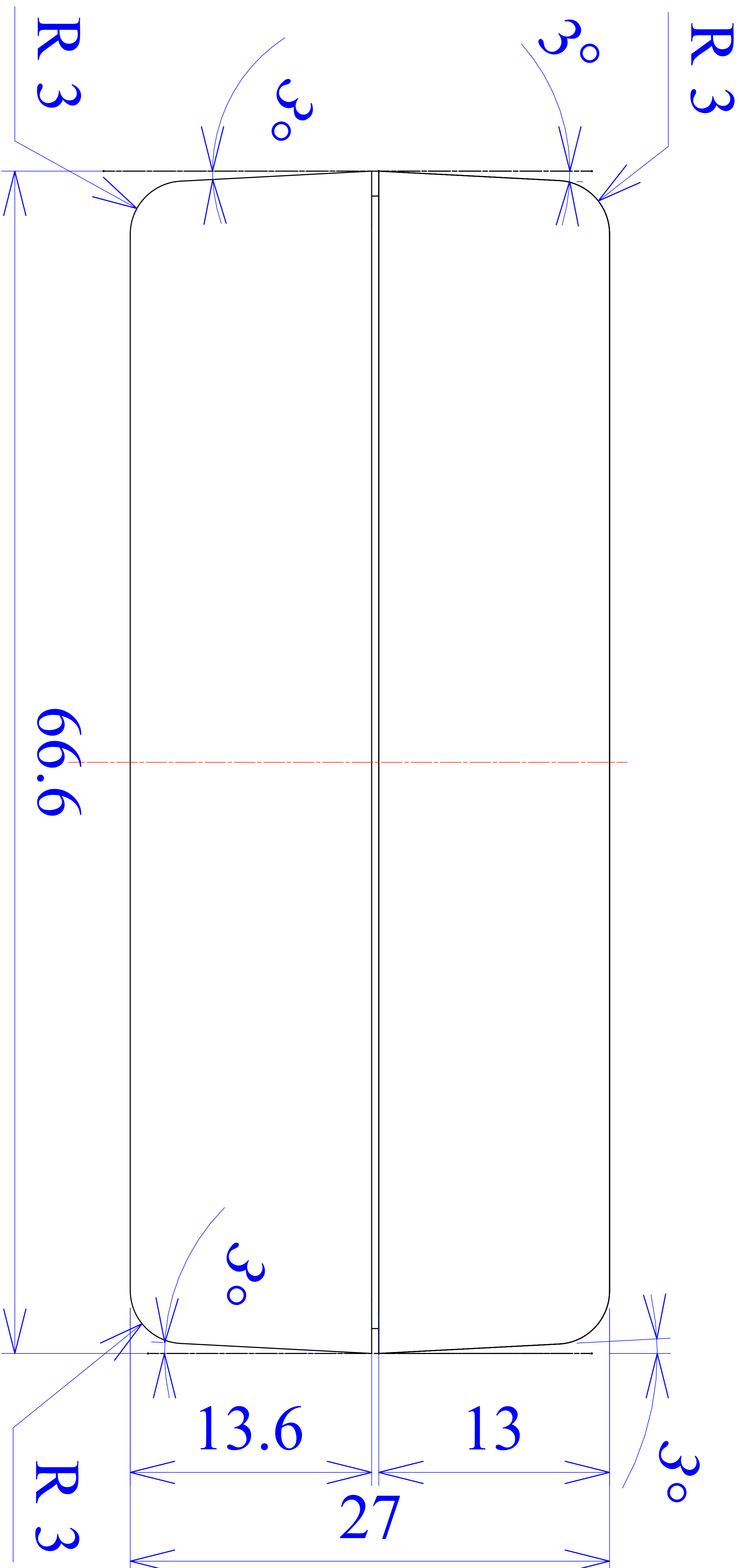

D - D

8x Ø 6.5

4x Ø 3.9

= 49.7 =

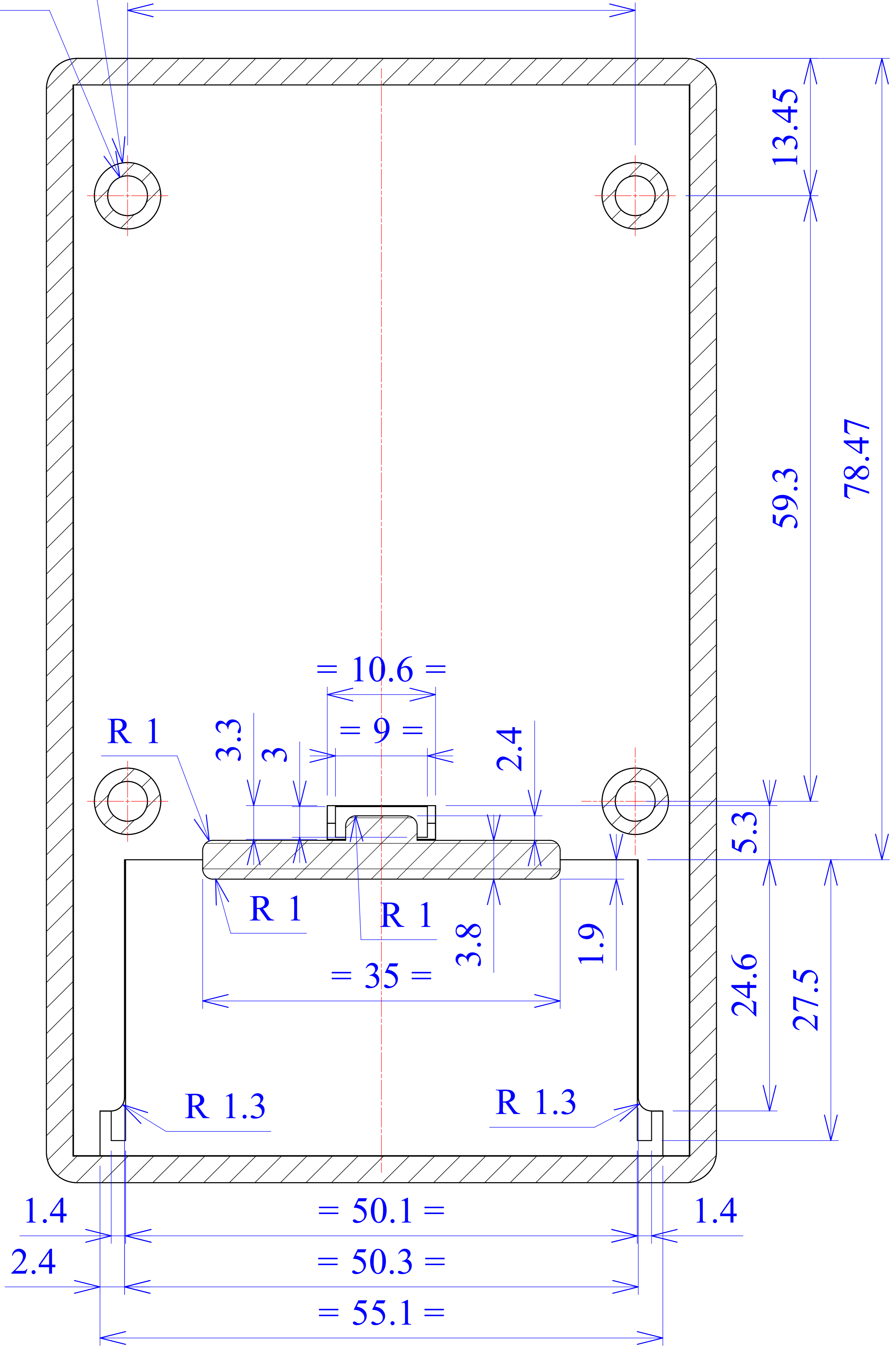

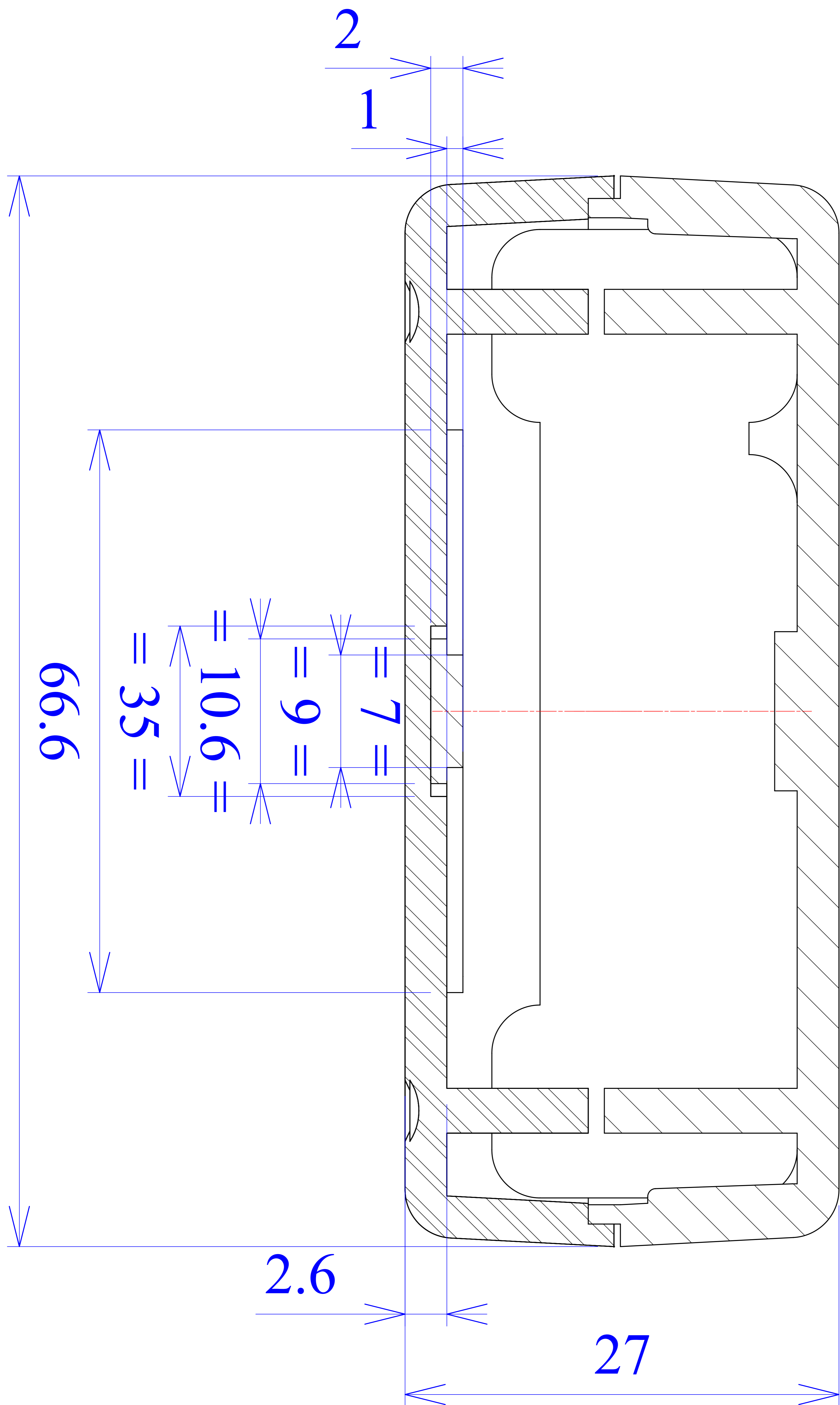

F - F