

Features

- Extremely high dv/dt capability
- 100% avalanche tested
- Gate charge minimized
- Very low intrinsic capacitances
- Very good manufacturing repeatability

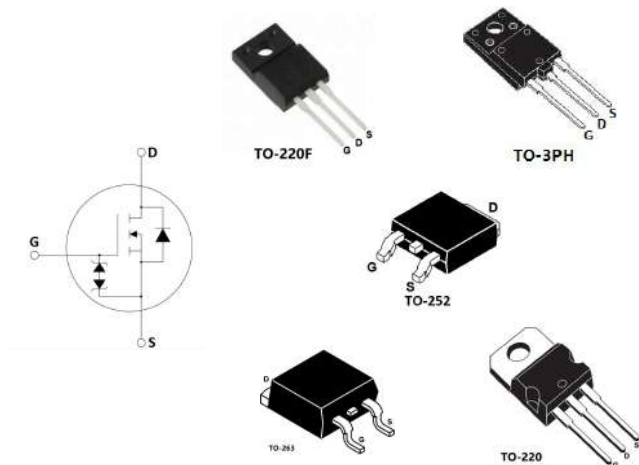

Applications

- Switching application

Electrical ratings(Absolute maximum ratings)

Parameter	Symbol	Value				Unit
		TO-3PH	TO-220F	TO-252	TO-220/ TO-263	
Drain-source voltage ($V_{GS}=0$)	V_{DS}	1000				V
Gate-source voltage	V_{GS}	± 30				
Avalanche current repetitive or not-repetitive (pulse width limited by T_j Max)	I_{AR}	5				A
Single pulse avalanche energy (starting $T_j=25^\circ\text{C}$ $I_d=I_{AR}$ $V_{dd}=50\text{V}$)	E_{AS}	583				mJ
Drain current (continuous) at $TC=25^\circ\text{C}$	I_D	5				A
Drain current (continuous) at $TC=100^\circ\text{C}$	I_D	3				
Drain current (pulsed)	I_{DM}	18	18	18	18	
Total dissipation at $TC=25^\circ\text{C}$	P_D	74	48	104	198	W
Operating junction temperature	T_J	-55 to 150				$^\circ\text{C}$
Storage temperature	T_{STG}					
Maximum lead temperature for soldering purpose	T_L	300				$^\circ\text{C}$

Electrical Characteristics($T_j=25^\circ\text{C}$ unless otherwise specified)

Parameter	Symbol	Test conditions	Min	Typ	Max	Unit
-----------	--------	-----------------	-----	-----	-----	------

On/off states						
Drain-source breakdown voltage	$V_{(BR)DSS}$	$I_D=1mA$ $V_{GS}=0$	1000			V
Zero gate voltage drain current ($V_{GS}=0$)	I_{DSS}	$V_{DS}=\text{Max rating}$			1	μA
		$T_C=125^\circ C$			50	μA
Gate body leakage current ($V_{GS}=0$)	I_{GSS}	$V_{GS}=\pm 20V$			± 100	nA
Gate threshold voltage	$V_{GS(th)}$	$V_{DS}=V_{GS}$ $I_D=250\mu A$	2.25	3	3.75	V
Static drain-source on resistance	$R_{DS(on)}$	$V_{GS}=10V$ $I_D=1A$		3.5	4.2	Ω
Forward transconductance	g_{fs}	$V_{DS} = 27 V, I_D = 5A$		5.6		S
Dynamic						
Parameter	Symbol	Test conditions	Min	Typ	Max	Unit
Input capacitance	C_{iss}	$V_{DS}=25V, f=1MHz, V_{GS}=0$		506		pF
Output capacitance	C_{oss}			59		
Reverse transfer capacitance	C_{rss}			3		
Total gate charge	Q_g	$V_{DD}=800V,$ $I_D=2.5A$ $V_{GS}=10V,$ $R_G = 4.7 \Omega$		18.68		nC
Gate-source charge	Q_{gs}			2.1		
Gate-drain charge	Q_{gd}			7.3		
Switching times						
Parameter	Symbol	Test conditions	Min	Typ	Max	Unit
Turn-on delay time	$t_{d(on)}$	$V_{DD} = 800 V,$ $I_D = 2.5 A,$ $R_G = 25\Omega,$ $V_{GS} = 10 V$		35.6		ns
Rise time	t_r			22.9		
Turn-off-delay time	$t_{d(off)}$			42.7		
Fall time	t_f			13.6		
Source Drain Diode						
Parameter	Symbol	Test conditions	Min	Typ	Max	Unit
Source Drain Current	I_{SD}			5		A
Source Drain Current(Pulsed)	I_{SDM}			18		A
Forward On Voltage	V_{SD}	$I_{SD}=5A, V_{GS}=0V$		0.8	1.2	V
Reverse Recovery Time	T_{rr}	$I_{SD}=5A,$ $di/dt=200A/\mu S$		1.02		us

Reverse Recovery Charge	Q _{rr}	V _R =100V, T _j =150°C		3.68		uC
Thermal data						
Parameter	Symbol	Value				Unit
		TO-3PH	TO-220F	TO-252	TO-220/ TO-263	
Thermal resistance junction max	R _{thj-case}	1.69	2.6	1.2	0.63	°C/W
Thermal resistance junction-ambient max	R _{tha-case}	47.4	58	68	35	°C/W

Order codes

Partnumber	Marking	Package
MS5N100	MS5N100	TO-3PH
MS5N100S	MS5N100S	TO-220F
MS5N100FT	MS5N100FT	TO-220
MS5N100FE	MS5N100FE	TO-263/D2PAK
MS5N100FD	MS5N100FD	TO-252/DPAK

Electrical characteristics (curves)

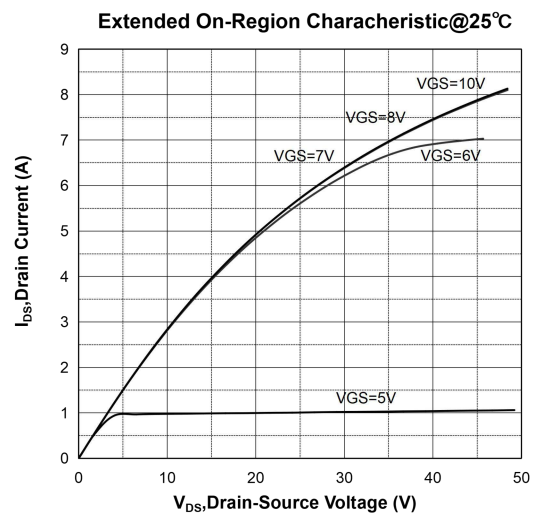
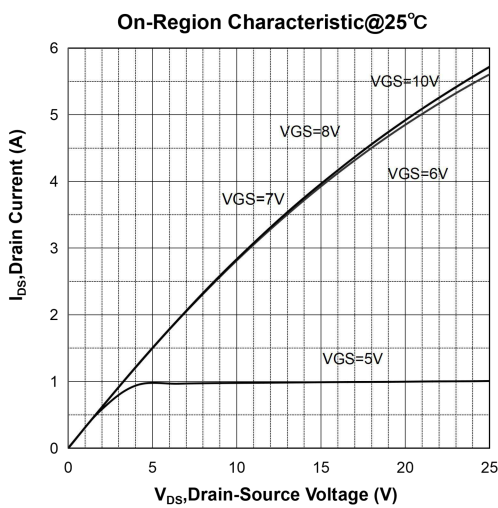

On-Region Characteristic@125°C

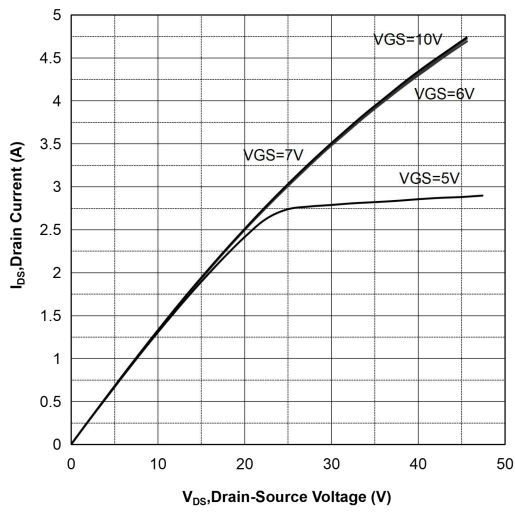

Transfer Characteristics

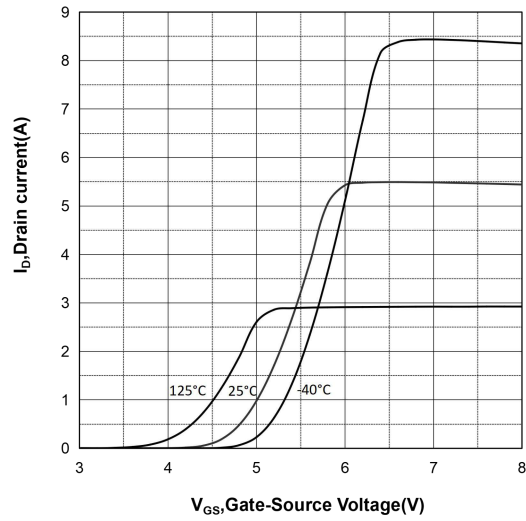

Transconductance

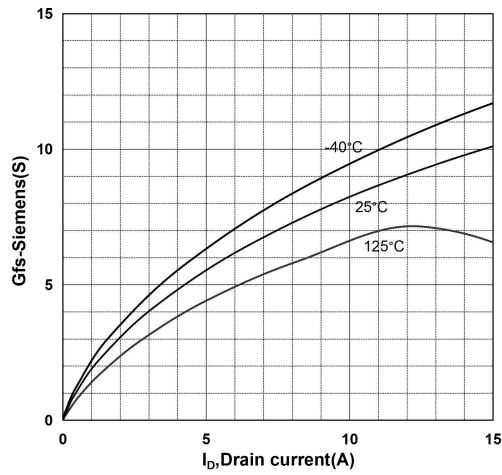

On-Resistance Variation vs Drain Current and Gate Voltage

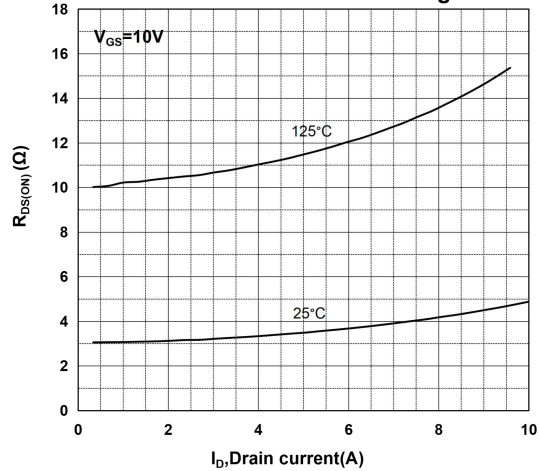

On-Resistance Variation vs Temperature

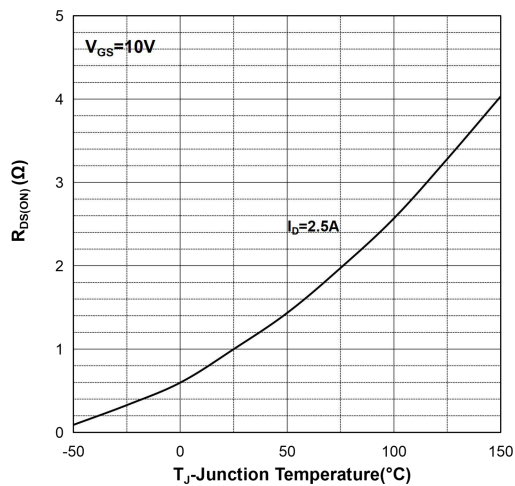

Body Diode Forward Voltage Variation with Source Current and Temperature

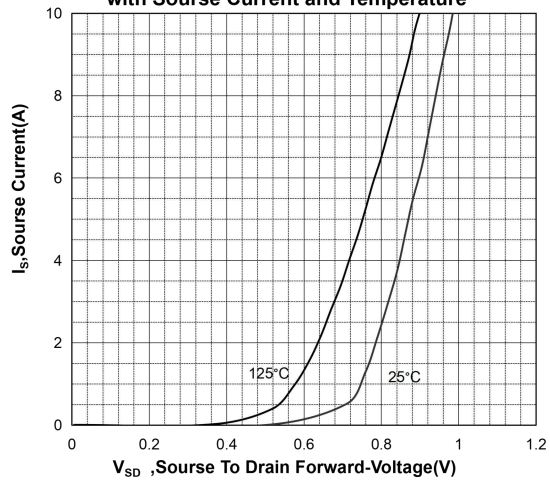

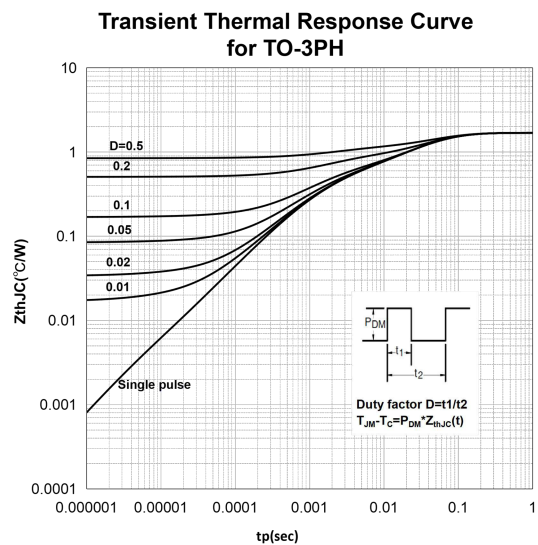
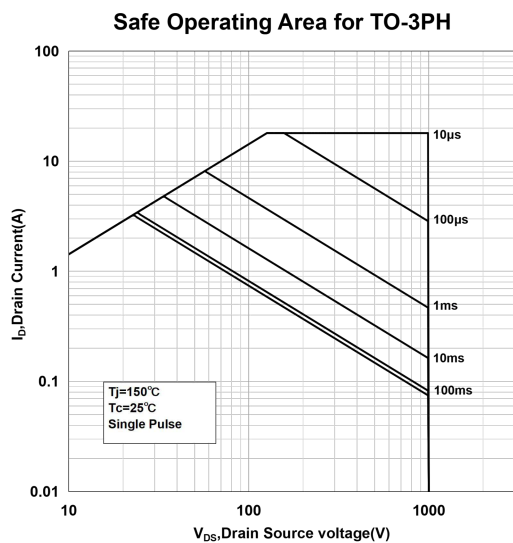
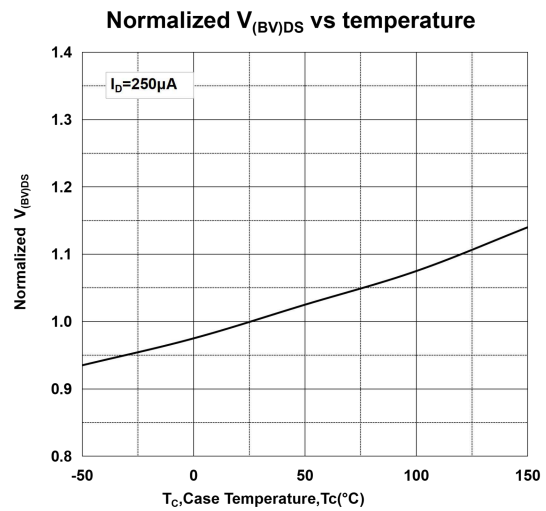
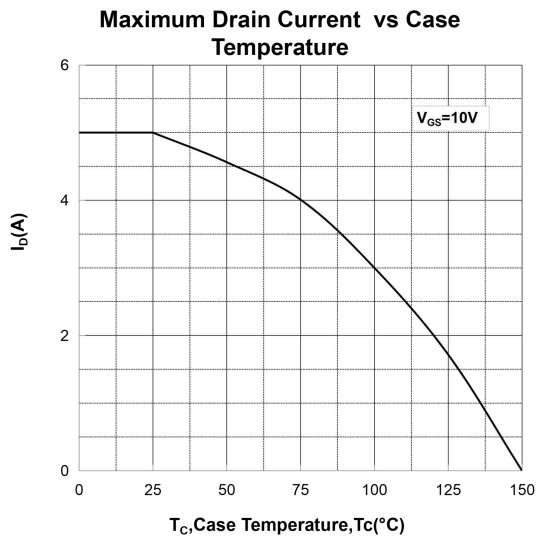
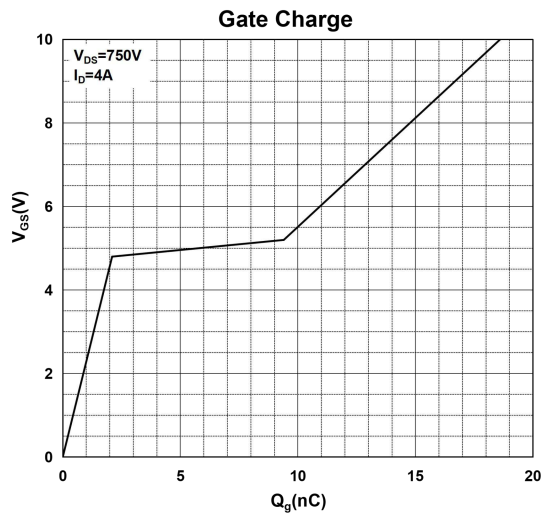
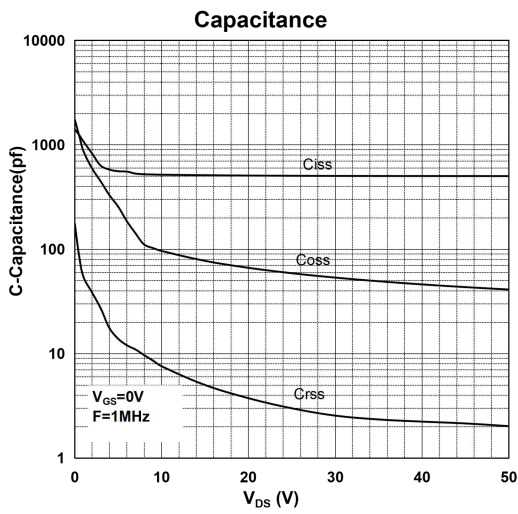

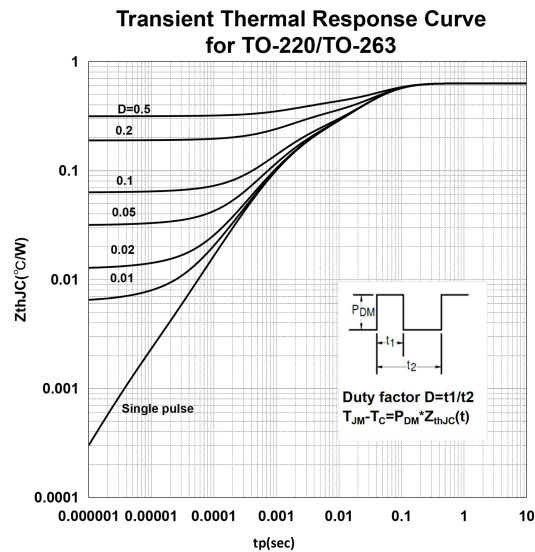
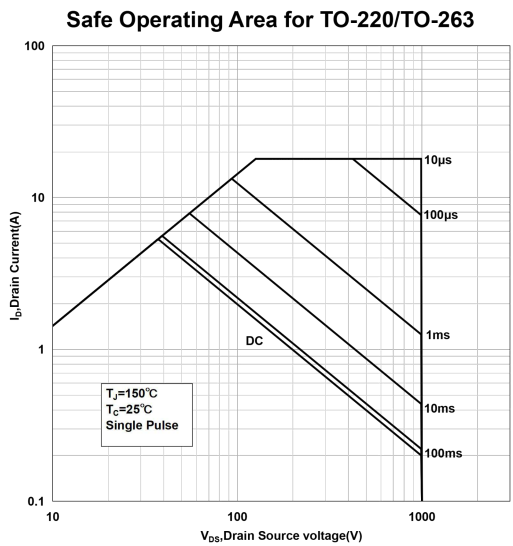
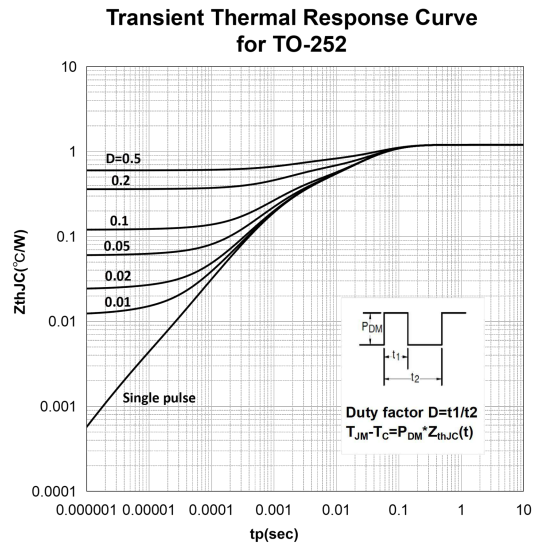
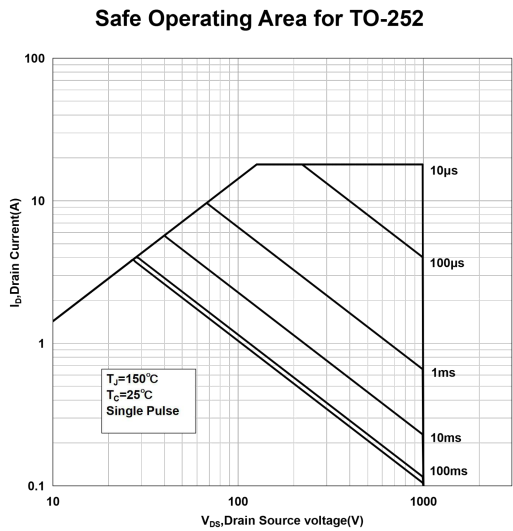
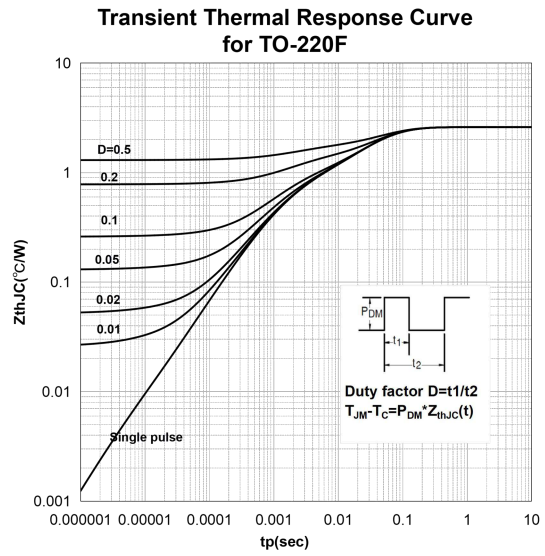
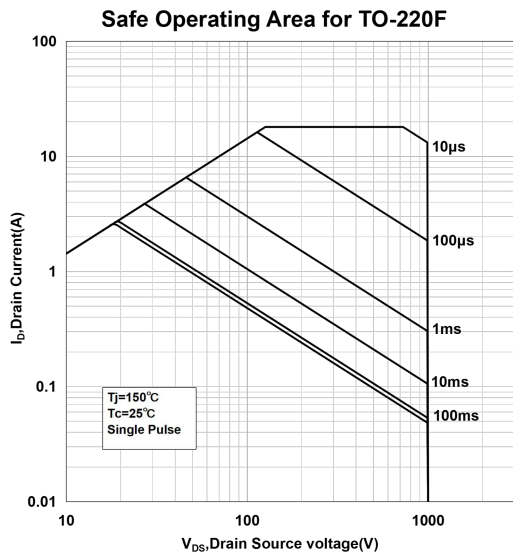

Package outline dimension

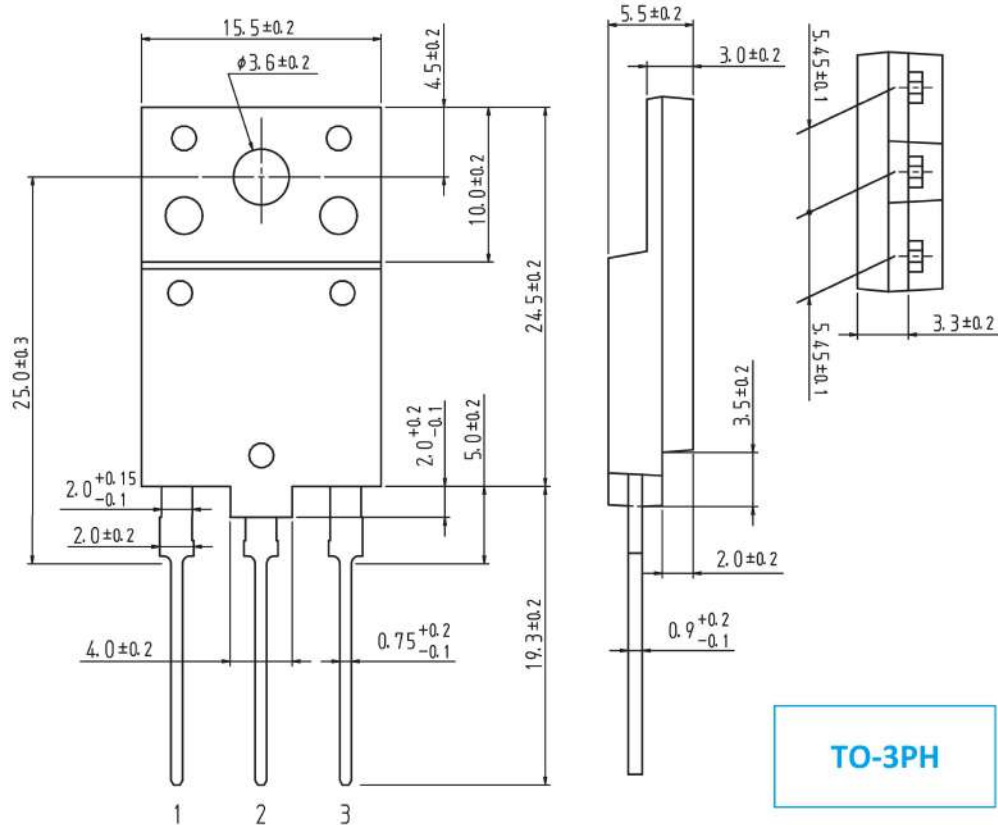

TO-3PH

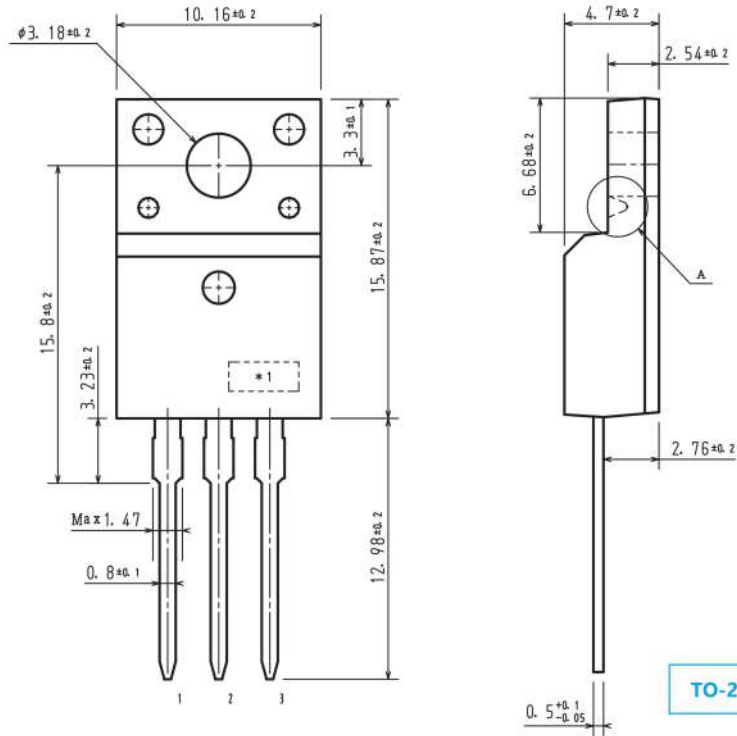

TO-220F

TO-263/D2PAK

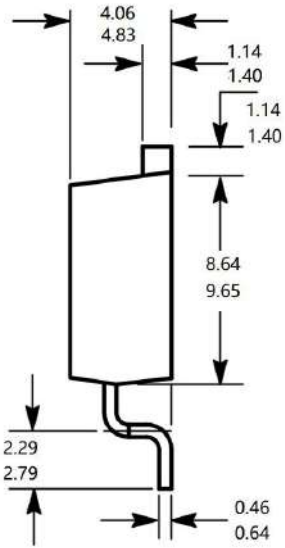
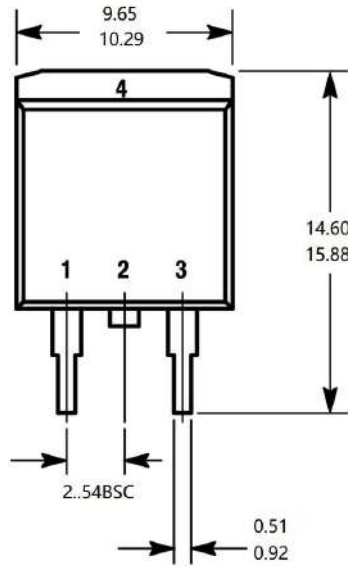

TO-263/D2PAK

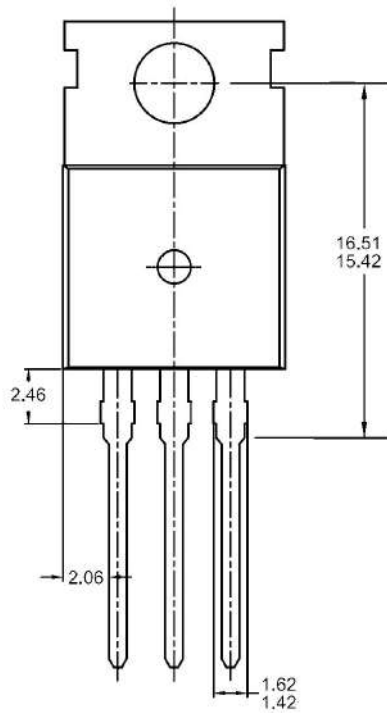

TO-220

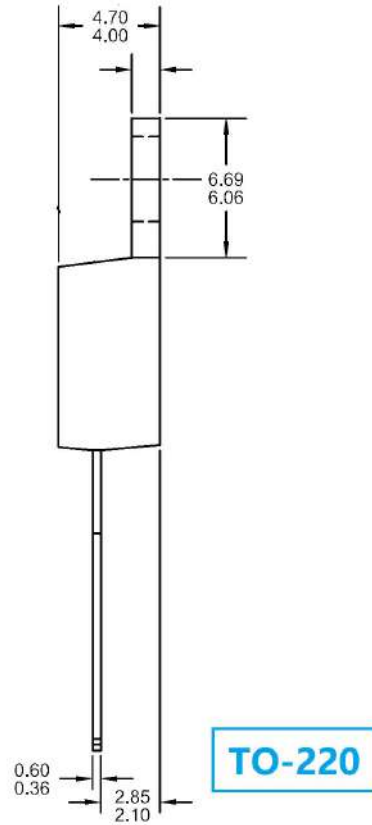

TO-220

